



COM100-V22-UEN-Ver11-202003

# COM100

## Communication Box

### User Manual

**SUNGROW**



# Contents

---

|   |    |
|---|----|
| <b>1 About this Manual</b> .....                    | 1  |
| 1.1 Intended Use.....                               | 1  |
| 1.2 Target Group.....                               | 1  |
| 1.3 How to Use This Manual.....                     | 1  |
| 1.4 Symbol Explanation.....                         | 1  |
| <b>2 Function Description</b> .....                 | 3  |
| 2.1 Function Introduction .....                     | 3  |
| 2.2 Main Features.....                              | 3  |
| 2.3 Dimensions .....                                | 3  |
| <b>3 Mechanical Installation</b> .....              | 5  |
| 3.1 Inspection before Installation.....             | 5  |
| 3.2 Location Requirements .....                     | 6  |
| 3.3 Installation Method.....                        | 6  |
| 3.3.1 Wall Mounting .....                           | 6  |
| 3.3.2 Ground Mounting .....                         | 7  |
| 3.3.3 Pole Mounting (optional) .....                | 8  |
| <b>4 Electrical Connection</b> .....                | 10 |
| 4.1 Waterproof Terminal Description .....           | 10 |
| 4.2 Internal Structure.....                         | 10 |
| 4.3 Preparation Before Connection.....              | 12 |
| 4.4 Electrical Connection Steps.....                | 13 |
| 4.4.1 Grounding .....                               | 13 |
| 4.4.2 RS485 Communication Terminal Connection ..... | 15 |
| 4.4.3 Optical Fibre (Optional) .....                | 16 |
| 4.4.4 AC 220V Connection .....                      | 16 |
| 4.4.5 PLC Port Connection .....                     | 17 |
| 4.5 Communication Methods .....                     | 21 |
| <b>5 Commissioning</b> .....                        | 22 |
| 5.1 Inspection before Commissioning.....            | 22 |
| 5.2 Commissioning Steps.....                        | 22 |

**6 Troubleshooting** ..... 24

**7 Appendix A: Related Parameters** ..... 25

**8 Appendix B: General Information** ..... 26

    8.1 Quality Guarantee ..... 26

    8.2 Contact Information ..... 26

# 1 About this Manual

This manual is valid for the communication box COM100 developed and manufactured by Sungrow Power Supply Co., Ltd.

The communication box COM100 is referred to as "COM100" for short unless otherwise specified.

## 1.1 Intended Use

This manual is intended to provide the reader with detailed information and description of the installation and operation about COM100.

## 1.2 Target Group

This manual is intended for technically qualified persons who need to install and operate COM100.

## 1.3 How to Use This Manual

Read this manual carefully before performing operation on the device. Keep the manual in a convenient place for future reference.

All rights reserved including the pictures, symbols, and markings used in this manual. Any reproduction or disclosure, even partially, of the contents of this manual is strictly prohibited without prior written authorization of Sungrow.

The content of the manual will be periodically updated or revised as per the product development. It is probably that there are changes in manuals for the subsequent module edition. If there any inconsistency, the actual product shall govern.

## 1.4 Symbol Explanation

This manual contains important safety and operational instructions that must be accurately understood and respected during the installation and maintenance of the equipment.

To ensure the optimum use of this manual, note the following explanations of the symbols used.

### DANGER

DANGER indicates a hazard with a high level of risk which, if not avoided, will result in death or serious injury.

**⚠ WARNING**

**WARNING** indicates a hazard with a medium level of risk which, if not avoided, could result in death or serious injury.

**⚠ CAUTION**

**CAUTION** indicates a hazard with a low level of risk which, if not avoided, could result in minor or moderate injury.

**NOTICE**

**NOTICE** indicates a situation which, if not avoided, could result in equipment or property damage.



**NOTE** indicates additional information, emphasized contents or tips to help you solve problems or save time.

## 2 Function Description

### 2.1 Function Introduction

The system block diagram is shown in the following figure.

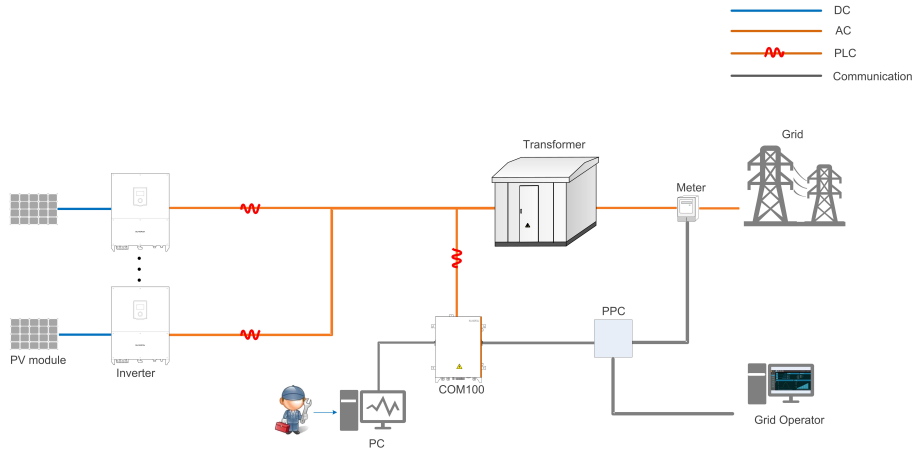

### 2.2 Main Features

#### Smart and flexible

- Integrating fiber switch and splice box, easy and flexible networking
- Integrating data collector, support of local intelligent commissioning
- Wall mounting, pole mounting, and ground mounting available, flexible installation

#### Simple and efficient

- Seamless connection to iSolarCloud, easy management of PV devices
- Built-in PLC communication, communication and management of string inverters without cable routing

#### Safe and reliable

- Equipped with electrical isolation and SPD protection, steady and reliable communication
- Ingress of protection IP65, long-term reliable outdoor operation

### 2.3 Dimensions

The external dimensions of COM100 are shown in the following figure.

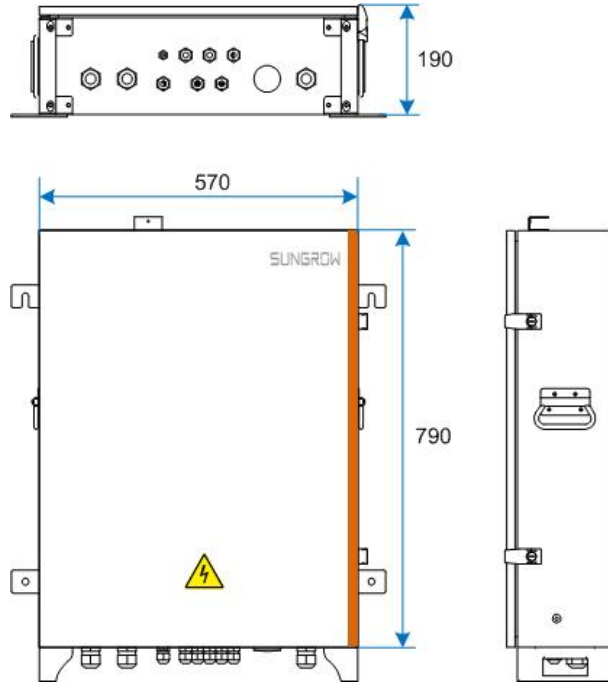



# 3 Mechanical Installation

## 3.1 Inspection before Installation

Check the scope of delivery for completeness according to the packing list. The following items should be included:

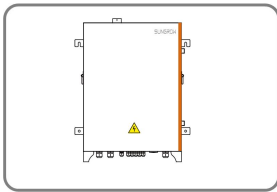

A



B

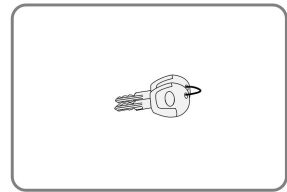

C



D

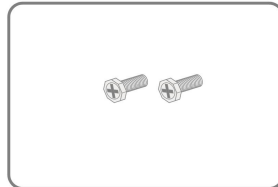

E

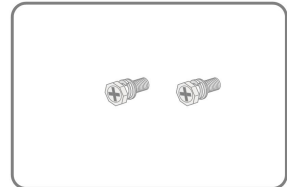

F

| Item | Description  | Sum |
|------|--|-----|
| A    | COM100   | 1   |
| B    | Documents, including certificate, warranty card, delivery inspection report, user manual, etc. | 1   |
| C    | Keys   | 2   |
| D    | M10 hexagon bolt assembly, used for wall-mounted installation and floor-mounted installation   | 4   |
| E    | M4x25 bolt, used for fixing antenna  | 1   |
| F    | M6x14 bolt assembly, used for fixing external PE point   | 1   |

### NOTICE

The device is carefully tested and inspected before delivery, but damage may be caused during shipping. Therefore, inspect the device before installation. If there any damage, contact the forwarding company or SUNGROW.

## 3.2 Location Requirements

- With the ingress of protection IP65, COM100 can be installed both indoors and outdoors (more commonly).
- Ambient temperature:  $-25^{\circ}\text{C}$  to  $+60^{\circ}\text{C}$ ; and ambient humidity:  $\leq 95\%$ . Excessive moisture can damage internal components.
- Take anti-moisture and anti-corrosion measures.

## 3.3 Installation Method

COM100 can be installed in two common manners: wall mounting and ground mounting.

According to different user requirements, Sungrow provides the third optional installation method: pole mounting. If necessary, specify your requirement when placing an order.

### **⚠ WARNING**

**Beware of the weight of COM100 throughout the installation process!  
Tilting or falling of the device due to inappropriate processing can cause personal injury!**

### 3.3.1 Wall Mounting

The installation dimensions of mounting ears on the back of COM100 are shown in the following figure.

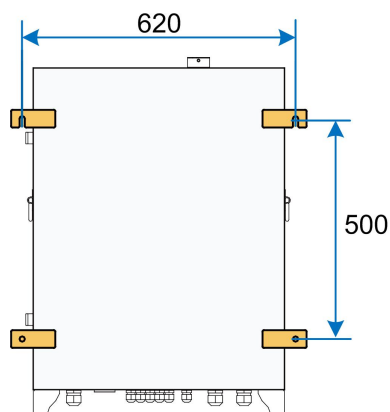

**step 1** Mark the hole locations on the installation wall according to the foregoing installation dimensions and drill holes on the marked locations according to bolt specifications.

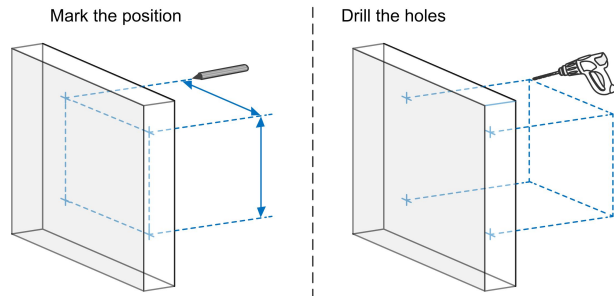

**step 2** Fasten the device in the order of M10 nut (A) , hanger (B), wall surface (C) and bolt (D), where the fastening torque is  $37 \pm 3\text{N.m}$ .

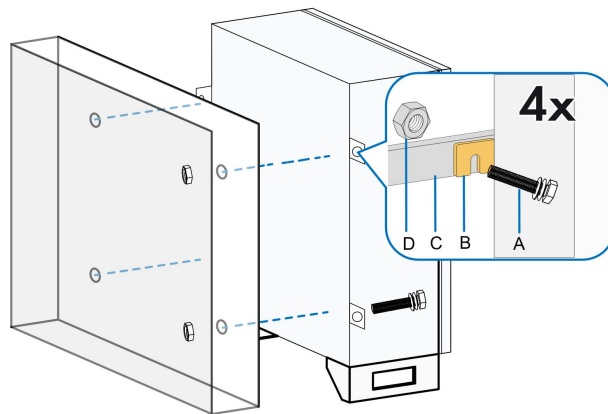

**step 3** Check to ensure COM100 is firmly in place.

-- End

### 3.3.2 Ground Mounting

For the ground mounting, the device is fixed via the foundation bolts pre-embedded in the foundation.

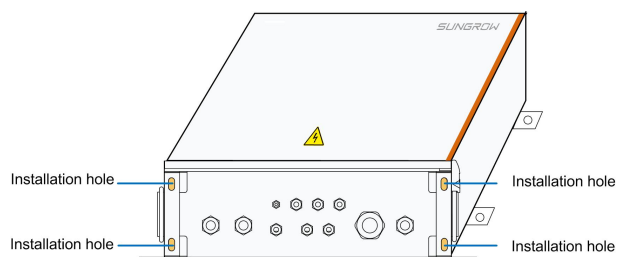

**step 1** Construct the foundation according to the exterior dimensions of COM100.

**step 2** Pre-embed the foundation bolts in the four foundation corners, where the bolts are of M10.

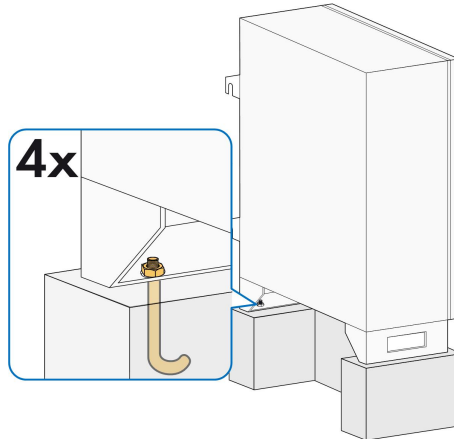

**step 3** Secure the mounting holes on bottom of COM100 to the foundation, where the fastening torque is  $37 \pm 3\text{N.m}$ .

-- End

### 3.3.3 Pole Mounting (optional)

COM100 supports pole mounting. If necessary, specify your requirements when placing an order. Sungrow will design according to actual installation conditions.

Accessories supplied with COM100 include matching screw combinations, nuts, brackets, clamps, and the like.

The installation steps are as follows:

**step 1** Fasten the mounting ears of COM100 onto the brackets by using the matching screw combinations, as shown in the figure below.

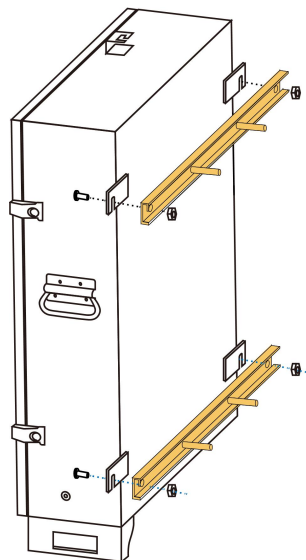

**step 2** Fix the brackets and the clamps by using the nuts.

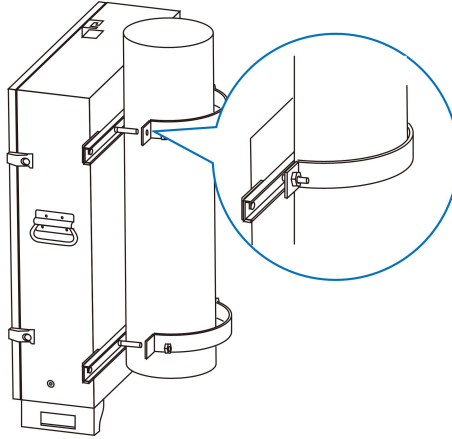

-- End

## 4 Electrical Connection

### 4.1 Waterproof Terminal Description

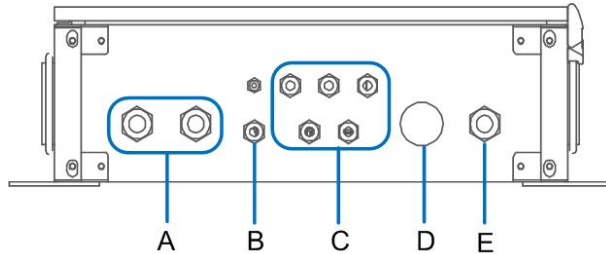

| Item | Mark  | Description   |
|------|---|---|
| A    | Optical fiber ports   | Waterproof terminals for optical fibers             |
| B    |  | Grounding waterproof terminal                       |
| C    | RS485   | Waterproof terminals for RS485 communication cables |
| D*   | Input AC 400V/480V/540V/800V  | Waterproof terminal for PLC communication cables    |
| E    | Input AC220V  | Waterproof terminal for AC 220V power cables        |



Note: The voltage level indicated by D\* is for reference only. Specifically, refer to the actual device purchased.

### 4.2 Internal Structure

The internal structure of COM 100 is shown in the following figure.

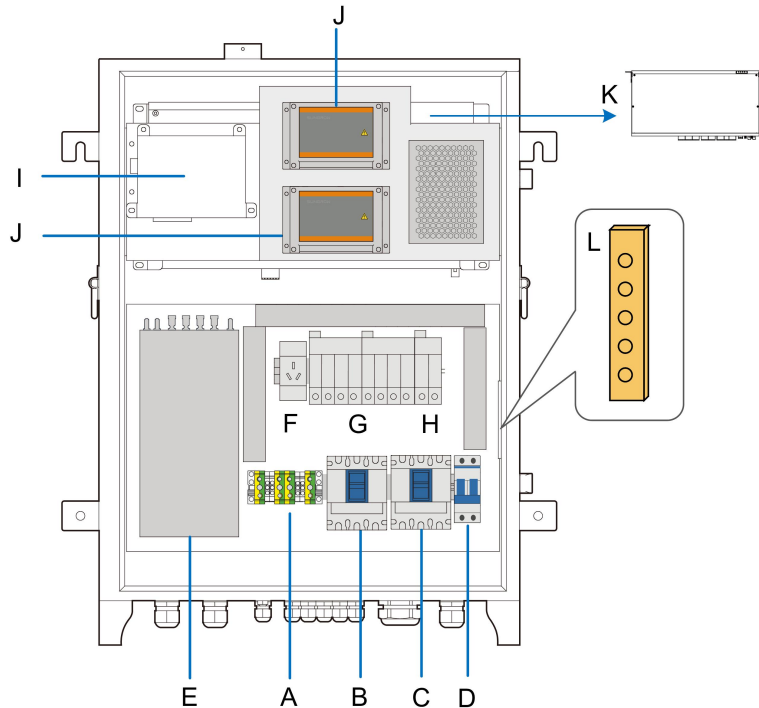

Internal components may differ as per selected product module. For details, refer to the actually received product.

| Item | Description                  | Recommended Cable Specification   | Source                       |
|------|------------------------------|---|------------------------------|
| A    | RS485 communication terminal | 2 x (0.75~1.5) mm <sup>2</sup> , outdoor ultraviolet protection STP                               | Beyond the scope of delivery |
| B    | PLC1 terminal                | 4mm <sup>2</sup> ~ 10mm <sup>2</sup> or 7~11AWG, withstanding voltage:                            | Beyond the scope of delivery |
| C    | PLC2 terminal                | Operating voltage < 800V<br>To gourd operating voltage ≥ 1,000V<br>Withstanding voltage ≥ 315 Vac |                              |
| D    | 220Vac power supply terminal | 1~1.5 mm <sup>2</sup> or 15~17AWG, outdoor ultraviolet protection cable                           | Beyond the scope of delivery |
| E    | Splice box                   | —   | —                            |

| Item | Description  | Recommended Cable Specification   | Source                       |
|------|--|---|------------------------------|
| F    | Troubleshooting socket, AC 220V, 800W (Max.)                                       | —   | —                            |
| G    | Surge protective device 1  | <ul style="list-style-type: none"> <li>Nominal voltage: 960Vac</li> <li>Nominal current: 6A</li> </ul>          | —                            |
| H    | Surge protective device 2  | <ul style="list-style-type: none"> <li>Nominal voltage: 385Vac</li> <li>Max. discharge current: 20kA</li> </ul> | —                            |
| I    | Switch (For more information, visit the website of the corresponding manufacturer) | —   | —                            |
| J    | PLC module   | —   | —                            |
| K    | Logger   | —   | —                            |
| L    | Grounding terminal   | 4mm <sup>2</sup> ~ 10mm <sup>2</sup> or 7~11AWG   | Beyond the scope of delivery |

### 4.3 Preparation Before Connection

**step 1** Open the cabinet. Unlock the door with the specific key, as shown in the following figure.

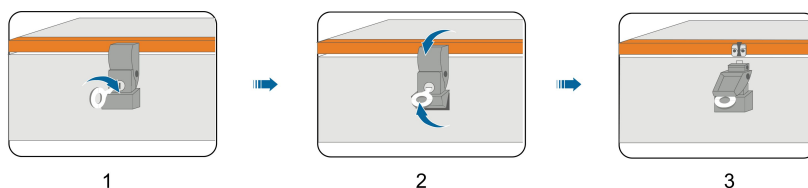

**step 2** Open the upstream input switch of COM100, and turn the power switch inside COM100 to the "OFF" position to ensure COM100 is voltage-free.

-- End



## 4.4 Electrical Connection Steps

### 4.4.1 Grounding

#### Safety Instructions

##### **⚠ WARNING**

The grounding cable must be grounded reliably! Otherwise,

- Lethal electrical shock can be caused when fault occurs!
- The device may be damaged by lightning!

#### Brief Introduction

COM100 is designed with two grounding terminals: grounding copper bar inside the cabinet and external PE point.

On site, connect both grounding terminals reliably.

#### Preparation before Installation

- Prepare the grounding cable.
- Strip the cable and crimp the OT terminal.

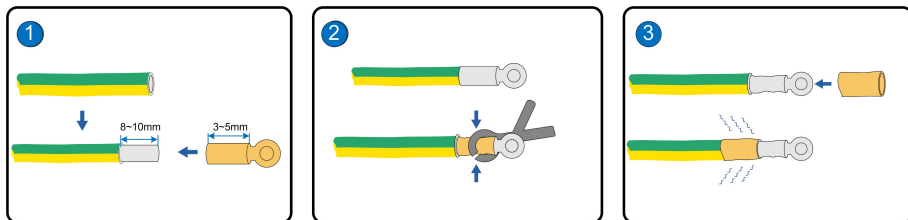

#### 4.4.1.1 Cooper Bar Grounding

##### Position Description

The grounding copper bar is located inside COM100, as shown in the figure below.

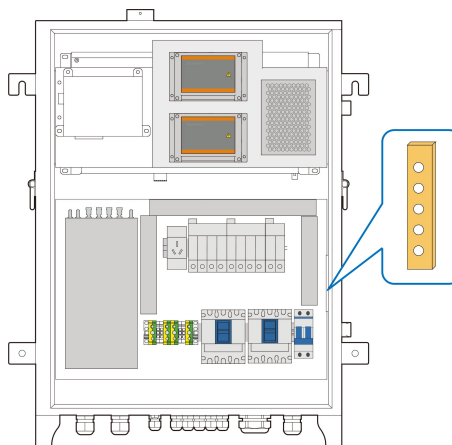

### Wiring Steps

**step 1** Unscrew the waterproof terminal “” at the bottom of COM100.

**step 2** Connect the yellow-green grounding cable led from outside to the grounding copper bar inside COM100 through the internal waterproof terminal “” .

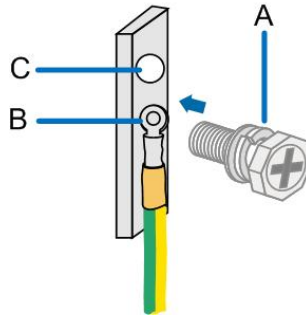

| Item | Definition       | Remark   |
|------|------------------|--|
| A    | M6 bolt assembly | It has been installed on the copper bar before delivery. |
| B    | OT terminal      | -  |
| C    | Grounding hole   | -  |

**step 3** Secure the cable with M6 bolt, where the fastening torque is  $7.5 \pm 0.5\text{N} \cdot \text{m}$ .

**step 4** Screw the waterproof terminal at the bottom of COM100.

-- End

#### 4.4.1.2 PE Point Grounding

##### Position Description

The external PE point of COM100 is shown by A in the figure below.

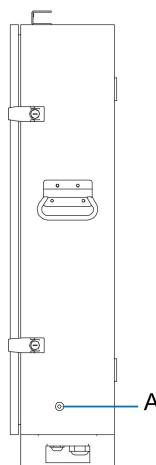

### Wiring Steps

Anchor the prepared OT terminal to the grounding hole with M6 x 14 bolt assembly, where the fastening torque is  $7.5 \pm 0.5\text{N} \cdot \text{m}$ .

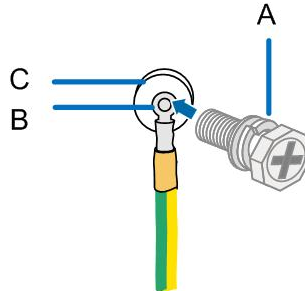

| Item | Definition     | Remark                                     |
|------|----------------|--|
| A    | M6 x 14 bolt   | Included in the scope of delivery assembly |
| B    | OT terminal    | -  |
| C    | Grounding hole | -  |

#### 4.4.2 RS485 Communication Terminal Connection

##### Cable Requirements

Cables connected to COM100 must be  $2 \times (0.75 - 1.5) \text{mm}^2$  in cross-sectional area.

##### Wiring Steps

**step 1** Unscrew the "RS485" waterproof terminal at the bottom of COM100.

**step 2** Connect the RS485 cable led from outside to the communication terminal inside COM100 through the "RS485" communication terminal.

**step 3** Strip the cable jacket with a wire stripper.

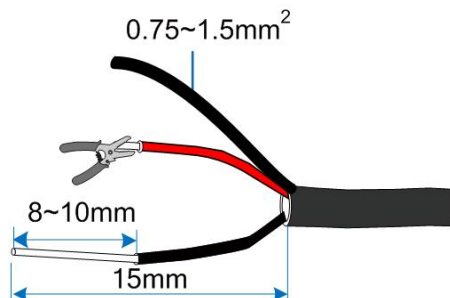

**step 4** Connect the cable to corresponding terminal, and secure it with a screwdriver, where the fastening torque ranges between  $0.5\text{N} \cdot \text{m}$  and  $0.6\text{N} \cdot \text{m}$ .

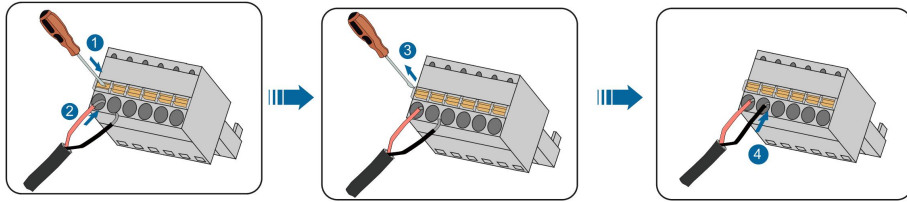

table 4-1 Terminal definition

| Mark | Definition  |
|------|---|
| GND  | Connected to RS485 cable shield                               |
| A    | Connected to RS485 – A, corresponding to upper-layer terminal |
| B    | Connected to RS485 – B, corresponding to lower-layer terminal |

**step 5** Gently pull the cable backwards to ensure firm connection.

**step 6** Screw the "RS485" waterproof terminal at the bottom of COM100.

-- End

#### 4.4.3 Optical Fibre (Optional)

##### Preparation before Installation

Before installation, prepare the required components. Components listed below are for reference only, and the actual situation may differ.

| No. | Component                                    |
|-----|--|
| 1   | Pigtail: 12-input single-mode ST, 600mm      |
| 2   | Jumper: Single-mode single-core ST-SC, 500mm |
| 3   | ST flange                                    |
| 4   | Network cable, 2,600mm                       |

##### Installation Steps

**step 1** Unscrew the waterproof terminal "Optical fiber ports", and lead the optical fibre through the terminal.

**step 2** Splice the optical fibre inside the splice box.



For details, contact SUNGROW.

**step 3** Screw the waterproof terminal "Optical fiber ports".

-- End

#### 4.4.4 AC 220V Connection

##### Preparation before Installation

- Before wiring AC 220V power supply, turn the micro circuit breaker to OFF position.
- Prepare the AC cable.

### Installation Steps

**step 1** Unscrew the waterproof terminal "Input AC220V", and lead the external power supply cable through the terminal.

**step 2** Strip the cable with a wire stripper.

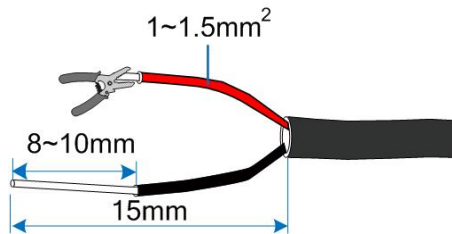

**step 3** Crimp the cord end terminal, where the recommended terminal model is: LT015008.

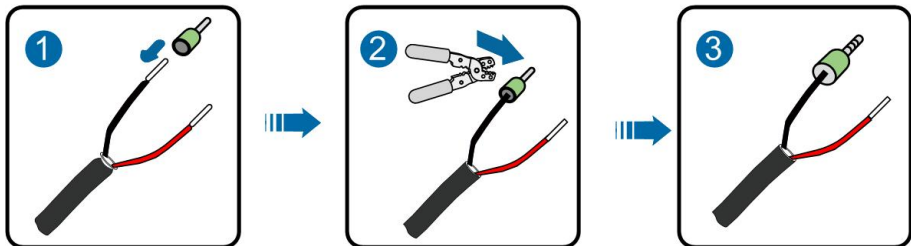

**step 4** Connect the cord end terminal to the corresponding terminal, and secure it with screw, where the fastening torque is  $2.0\text{N} \cdot \text{m}$ .



**step 5** Screw the waterproof terminal "Input AC220V".

-- End

#### 4.4.5 PLC Port Connection

##### Wiring Diagram

COM100 can be connected to double-split transformer or double-winding transformer, as shown in the figures below.

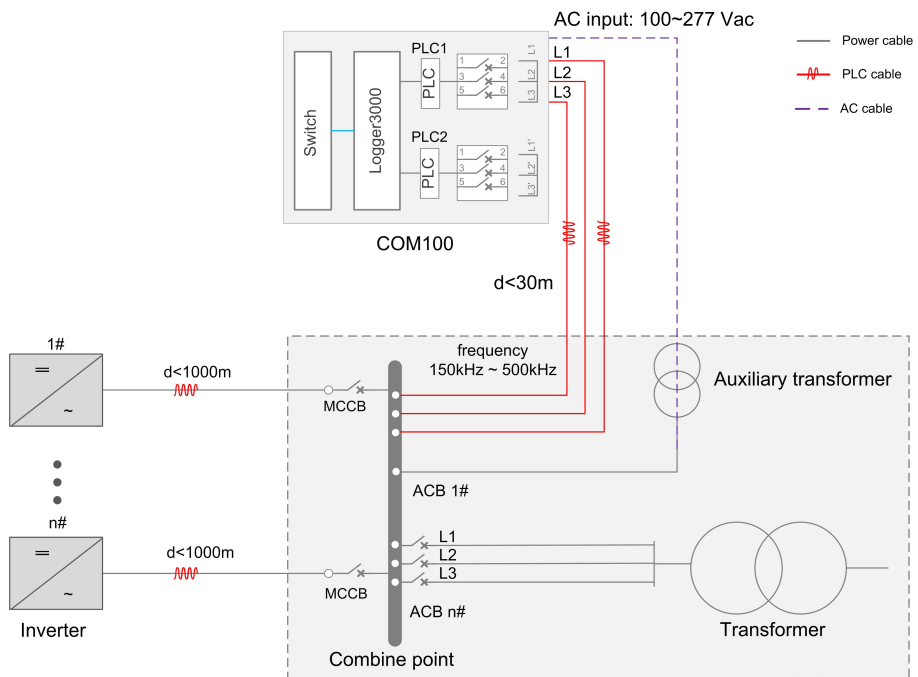

figure 4-1 Connection to double-winding transformer

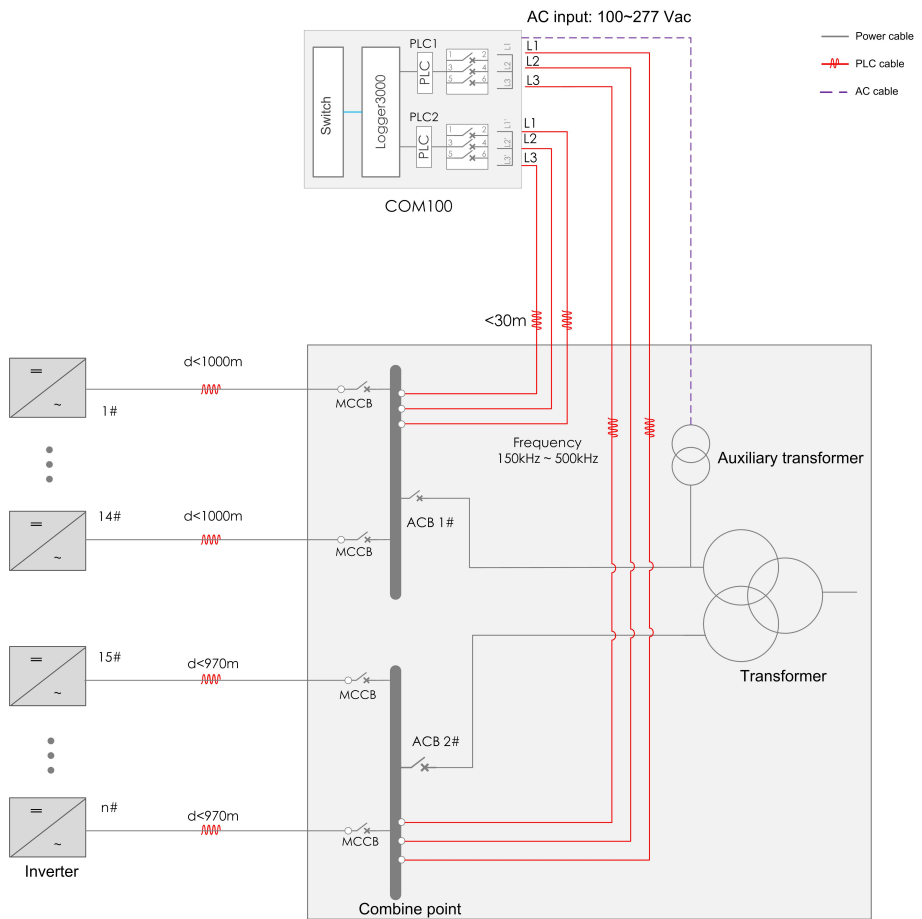

figure 4-2 Connection to double-split transformer

### Preparation before Installation

Before wiring, ensure that upstream AC switches and circuit breakers inside COM100 are all disconnected.

### Installation Steps

**step 1** Unscrew the waterproof terminal "Input AC 400V/480V/540V/800V" at the bottom of COM100, and lead external AC cable through the terminal.

**step 2** Strip the cable jacket with a wire stripper, as shown in the figure below.

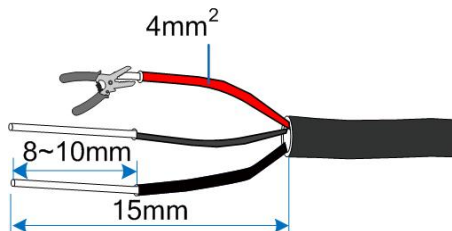

**step 3** Crimp the OT terminal, whose specification is recommended to be OT2.5-6.

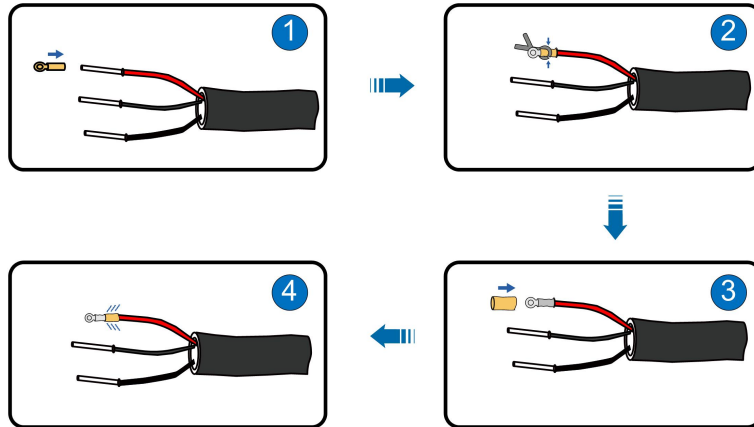

step 4 Connect the cable to corresponding terminal.

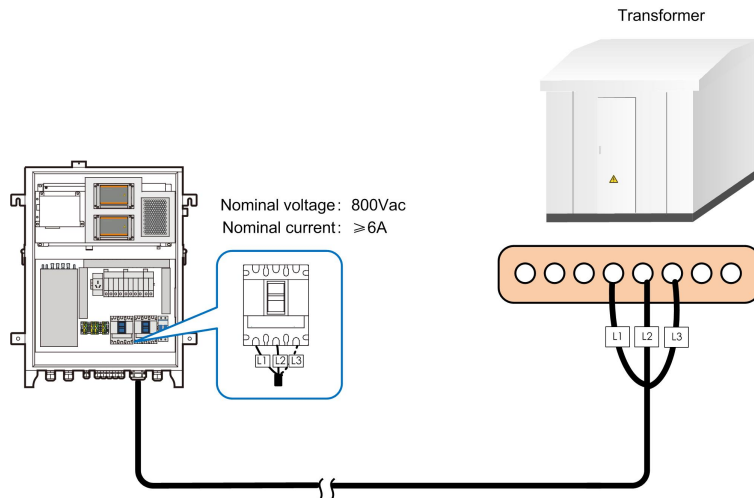

figure 4-3 Three-phase three-wire connection



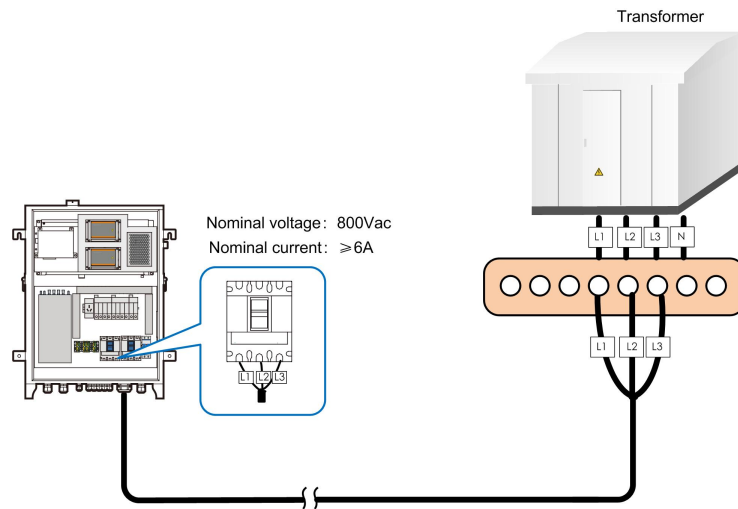

figure 4-4 Three-phase four-wire connection

**step 5** Check the cable for correct connection, and then secure it with screw, where the fastening torque is 5.5N · m.

-- End



For parameters of the circuit breaker on transformer side, refer to those of the circuit breaker inside COM100 shown in the figure above.

## 4.5 Communication Methods

The COM100 can collect the operating data of the inverter, transformer and other equipment in the system and upload it to the remote monitoring system.

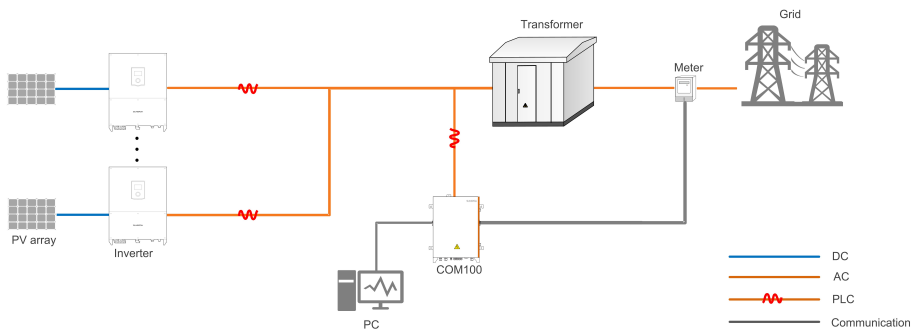

Users can check the operation information and set the parameters via the remote monitoring system, for more details, refer to .

## 5 Commissioning

### 5.1 Inspection before Commissioning

| No. | Inspection item  |
|-----|--|
| 1   | All cables are intact, well-insulated, and appropriately dimensioned.                        |
| 2   | All cables are connected correctly and firmly.   |
| 3   | The polarity of the power supply cable is correct. The grounding cable is reliably grounded. |

### 5.2 Commissioning Steps

#### Commissioning Steps

| Item | Description  |
|------|--|
| 1    | Connect the input-side circuit breaker of the PLC inside COM100.   |
| 2    | Connect the control switch of 220V power supply.   |
| 3    | Check whether the switch and 24V switch-mode power supply operate normally.  |
| 4    | Observe running indicators of Logger3000. If the PWR indicator keeps steady on, and the RUN indicator flickers once every second, it indicates normal operation. |

#### Configure Logger3000 through WEB Interface

| Item | Description  |
|------|--|
| 1    | Connect PC to the Ethernet port of the switch inside COM100 by using a network cable. IP of the Ethernet port is 13.13.13.13 by default.   |
| 2    | Set IP of the PC, which should be in the same network segment as that of the ETH2 port of the Logger3000. For example, it can be set to 13.13.13.x (x ranges between 1 and 255, except 13), and the subnet mask can be set to 255.255.255.0. |
| 3    | Enter the IP of the Logger3000, such as 13.13.13.13, in the PC address bar, to enter the corresponding Web interface.  |
| 4    | Configure serial port parameters.  |
| 5    | Add device.  |
| 6    | Configure device IP.   |

| Item | Description  |
|------|--|
|      | Configure iSolarCloud address if inverter data needs to be uploaded to iSolarCloud.  |
| 7    | <p>Accessed iSolarCloud site is "Chinese Server" by default.</p> <p>In mainland China, set the site to "Chinese Server".</p> <p>In Europe, set the site to "European Server".</p> <p>In other regions, set the site to "International Server".</p> |
| 8    | Access the Web interface of Logger3000 and check whether running data of string inverters manufactured by SUNGROW is normal.   |
| 9    | Create power plants through iSolarCloud App, and check whether data displayed on iSolarCloud is normal.  |

#### Additional Description

To create power plant through iSolarCloud App, download and install the App and then proceed as follows:

- 1 Log into the Web interface of Logger3000 and click "About", to obtain the QR code.



- 2 Scan the QR code with the App or manually input the S/N to add communication device.

For more details, refer to the user manual of Logger3000 which can be obtained by scanning the foregoing QR code.

## 6 Troubleshooting

| Fault  | Possible Cause  | Corrective Measures   |
|--|---|---|
| According to the background monitoring device, some device in the PV array is abnormally disconnected. | 1. RS485 cable is abnormal.                               | 1. Measure the voltage between RS485 – A and RS485 – B with a multimeter, and check whether the voltage is about 5V.  |
|  | 2. There are repeated device addresses in the PV array.   | 2. Check whether there are repeated device addresses.   |
|  | 3. Parameters of Logger3000 are incorrectly configured.   | 3. Check, through the WEB interface “ <b>Device Management</b> ” -> “ <b>Device Operation</b> ” , whether corresponding port of the device is set to "PLC". |
|  | 4. Master and slave node modules of the PLC are abnormal. | 4. Check whether the indicator D12 keeps steady red while the indicator D8 flickers green. If not, the modules are abnormal.                                |
|  | 5. Other causes   | If the fault persists, please contact SUNGROW.  |
| According to the background monitoring device, some device in the PV array is unstably connected.      | 1. There are repeated device addresses in the PV array.   | 1. Check whether there are repeated device addresses.   |
|  | 2. Parameters of Logger3000 are incorrectly configured.   | 2. Check, through the WEB interface “ <b>Device Management</b> ” -> “ <b>Device Operation</b> ” , whether corresponding port of the device is set to "PLC". |
|  | 3. Other causes   | If the fault persists, please contact SUNGROW.  |

## 7 Appendix A: Related Parameters

| Configuration                      |   |
|------------------------------------|---|
| Logger                             | Logger3000  |
| Fibre channel switch<br>(Optional) | 2 optical ports, 6 electrical ports   |
| Splice box (Optional)              | 2-input, 12-output, SC single-mode  |
| Power supply                       | 100 – 277 Vac, 50/60 Hz   |
| PLC port input voltage             | 400 Vac/480 Vac/540 Vac/800 Vac   |
| PLC power supply voltage           | <ul style="list-style-type: none"> <li>In-built master node of Logger3000: 15 Vdc</li> <li>Master node of PLC module: 24 Vdc</li> </ul> |
| Power consumption                  | <ul style="list-style-type: none"> <li>Average power consumption: 30W</li> <li>Max. power consumption: 40W</li> </ul>                   |
| Ambient parameter                  |   |
| Operating temperature              | - 25°C – +60°C  |
| Storage temperature                | - 30°C – +70°C  |
| Operating humidity                 | 0 – 95%, non-condensing   |
| Operating altitude                 | 0 – 3,000 m   |
| Protection degree                  | IP65  |
| Mechanical parameters              |   |
| Dimensions (W x H x D)             | 570 × 790 × 190 mm  |
| Weight                             | 32 kg   |
| Installation method                | Pole mounting, ground mounting, and wall mounting   |
| Cable entry mode                   | Bottom entry  |

## 8 Appendix B: General Information

### 8.1 Quality Guarantee

SUNGROW shall service or replace the faulty product for free within the warranty period.

#### **Evidence**

Within the warranty period, SUNGROW shall require the customer to present the purchase invoice and date. The trademark on the product shall be clearly visible, and SUNGROW shall hold no liability if otherwise.

#### **Exclusion of Liability**

- The free warranty period for the whole machine/components has expired
- The device is damaged during transport
- The device is installed, altered, or operated incorrectly
- The device operates in an environment harsher than that described in this manual
- The fault or damage is caused due to installation, maintenance, alteration, or disassembly performed by persons not from SUNGROW
- The fault or damage caused by using non-standard components or software or using components or software not from SUNGROW
- The installation and operation do not comply with stipulations of relevant international standards
- The damage is caused by unpredictable factors

For the foregoing faults or damages, SUNGROW can provide a paid service at the request of the client after judgment.



The dimensions and parameters of the device are subject to changes without notification, and reference can be made to the latest document.

#### **Software Licenses**

- It is prohibited to use data contained in firmware or software developed by SUNGROW, in part or in full, for commercial purposes by any means.
- It is prohibited to perform reverse engineering, cracking, or any other operations that compromise the original program design of the software developed by SUNGROW.

### 8.2 Contact Information

Should you have any question about this product, please contact us.

We need the following information to provide you the best assistance:

- Type of the device
- Serial number of the device
- Fault code/name
- Brief description of the problem

|  |  |
|--|--|
| China (HQ)   | Australia  |
| Sungrow Power Supply Co., Ltd  | Sungrow Australia Group Pty. Ltd.  |
| Hefei  | Sydney   |
| +86 551 65327834   | +61 2 9922 1522  |
| <a href="mailto:service@sungrowpower.com">service@sungrowpower.com</a>                   | <a href="mailto:service@sungrowpower.com.au">service@sungrowpower.com.au</a> |
| Brazil   | France   |
| SungrowDo Brasil   | Sungrow France – Siege Social  |
| Sao Paulo  | Paris  |
| +55 11 2366 1957   |  |
| <a href="mailto:latam.service@sa.sungrowpower.com">latam.service@sa.sungrowpower.com</a> | <a href="mailto:service.france@sungrow.co">service.france@sungrow.co</a>     |
| Germany  | Greece   |
| Sungrow Deutschland GmbH   | Service Partner – Survey Digital   |
| M ü nchen  | +30 2106044212   |
| +49 89 324 914 761   | <a href="mailto:service.greece@sungrow.co">service.greece@sungrow.co</a>     |
| <a href="mailto:service.germany@sungrow.co">service.germany@sungrow.co</a>               |  |
| India  | Italy  |
| Sungrow (India) Private Limited  | Sungrow Italy  |
| Gurgaon  | Milano   |
| +9108041201350   | <a href="mailto:service.italy@sungrow.co">service.italy@sungrow.co</a>       |
| <a href="mailto:service@in.sungrowpower.com">service@in.sungrowpower.com</a>             |  |
| Japan  | Korea  |
| Sungrow Japan K.K.   | Sungrow Power Korea Limited  |
| Tokyo  | Seoul  |
| + 81 3 6262 9917   | +827077191889  |
| <a href="mailto:japanservice@jp.sungrowpower.com">japanservice@jp.sungrowpower.com</a>   | <a href="mailto:service@kr.sungrowpower.com">service@kr.sungrowpower.com</a> |
| Malaysia   | Philippines  |
| Sungrow SEA  | Sungrow Power Supply Co., Ltd  |
| Selangor Darul Ehsan   | Mandaluyong City   |
| +6019897 3360  | +639173022769  |
| <a href="mailto:service@my.sungrowpower.com">service@my.sungrowpower.com</a>             | <a href="mailto:service@ph.sungrowpower.com">service@ph.sungrowpower.com</a> |

|   |   |
|---|---|
| Thailand<br>SungrowThailand Co., Ltd.<br>Bangkok<br>+66891 246053<br><a href="mailto:service@th.sungrowpower.com">service@th.sungrowpower.com</a> | Spain<br>Sungrow Ib é rica S.L.U.<br>Navarra<br><a href="mailto:service.spain@sungrow.co">service.spain@sungrow.co</a>  |
| Romania<br>Service Partner - Elerex<br>+40 241 762250<br><a href="mailto:service.romania@sungrow.co">service.romania@sungrow.co</a>               | Turkey<br>Sungrow Deutschland GmbH Turkey<br>Istanbul Representative Bureau<br>Istanbul<br>+90 2127318883<br><a href="mailto:service.turkey@sungrow.co">service.turkey@sungrow.co</a> |
| UK<br>Sungrow Power UK Ltd.<br>Milton Keynes<br>+44 (0) 0908 414127<br><a href="mailto:service.uk@sungrow.co">service.uk@sungrow.co</a>           | U.S.A, Mexico<br>Sungrow USA Corporation<br>PhoenixArizona<br>+1833 7476937<br><a href="mailto:techsupport@sungrow-na.com">techsupport@sungrow-na.com</a>                             |
| Vietnam<br>Sungrow Vietnam<br>Hanoi<br>+84 918 402 140<br><a href="mailto:service@vn.sungrowpower.com">service@vn.sungrowpower.com</a>            |   |